



Compressed Air System Troubleshooting

Section 05-01-06

Komatsu has made every effort to make this manual as accurate as possible based on the information available at the time of publication and printing. Continuous improvement and advancement of product design may cause changes to machines, which may not have been included in this publication. Komatsu reserves the right to make changes and improvements at any time. To ensure the most current information, please contact your service center.

Table of Contents

Safety	3
Safety, Warnings and Cautions	3
Air Compressor	5
Compressed Air System Leak Detection	7
LINCS II Troubleshooting Conditions	8
Troubleshooting Procedure to Isolate a Difficult to Find Air Leak	17

List of Figures

Figure 1. Compressor and dryer requirements.....	5
Figure 2. Normal compressor duty cycle	6
Figure 3. Compressor duty cycle too high duty cycle and too little time off	6
Figure 4. Diaphragm valve.....	7
Figure 5. Ultrasonic leak detector (P/N R4264953).....	7
Figure 6. LINCS II channel selection screen (typical screen).....	8
Figure 7. LINCS II charting screen (typical screen).....	9
Figure 8. Complete air system.....	11
Figure 9. Air distribution system	12
Figure 10. Brake system	13
Figure 11. Hydraulic tank system	14
Figure 12. KLENZ™ system	15

This Page Intentionally Left Blank

Safety

This publication contains special instructions that pertain to safety, operation, maintenance, and repair of the machine. Listed below are the signal words and symbols that precede these instructions and their meanings:

DANGER

- The danger label indicates a hazardous situation which, if not avoided, will result in death or serious injury.

WARNING

- The warning label indicates a hazardous situation which, if not avoided, could result in death or serious injury.

CAUTION

- The caution label, used with the safety alert symbol indicates a hazardous situation which, if not avoided, could result in minor or moderate injury (includes the safety alert symbol .

CAUTION

- The caution label (without safety alert symbol) is used to address practices not related to personal injury only equipment damage.

NOTICE

The NOTICE graphic is to indicate areas of importance to the reader that are not related to personal injury or machine damage.

Safety, Warnings and Cautions

CAUTION

EQUIPMENT DAMAGE

- Testing of the KLENZ™ system, air brakes, air horn and other air systems for flow requirements with flow meters shows that the compressor currently in use does not have the capacity to cope with a major continuous air leak. All leaks should be fixed as soon as possible.

This Page Intentionally Left Blank

Air Compressor

The duty cycle of a compressor should be less than 25%. This means that if the compressor is on for 15 seconds building air pressure then it should be off for at least 45 seconds to cool down. High duty cycle means that the air compressor is on for a higher percentage of time, runs hotter, and contributes to shorter life.

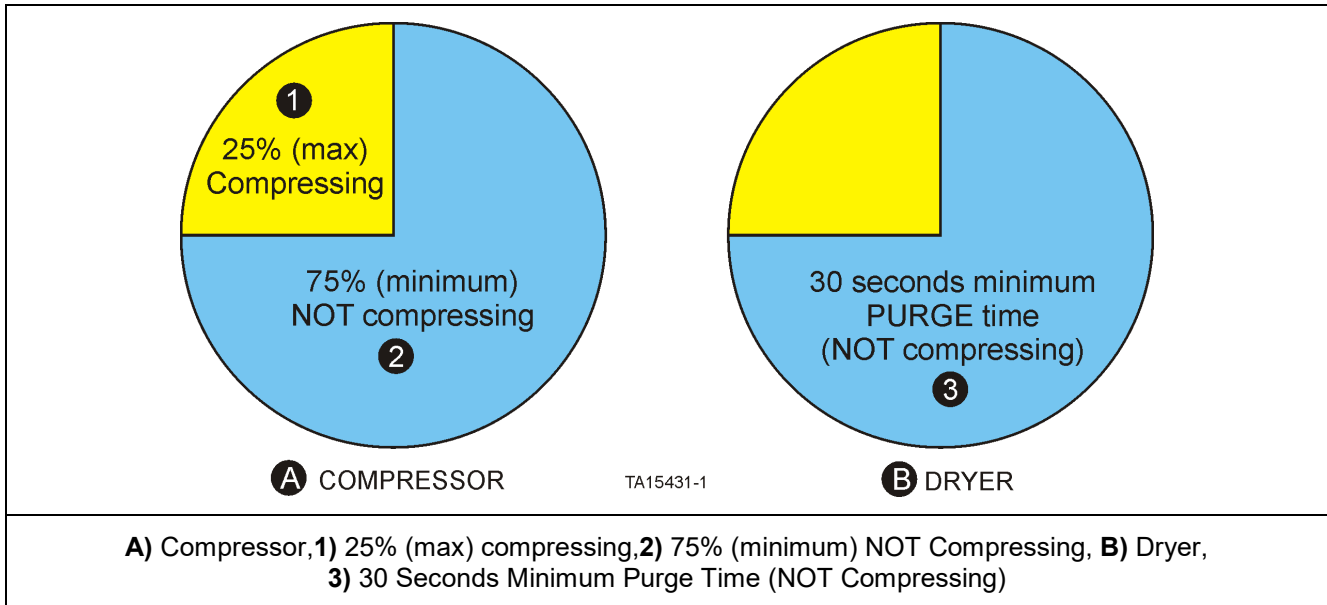

Figure 1. Compressor and dryer requirements

The compressor must be in an off state for more than 30 seconds to allow the air dryer to function properly.

The nominal pressure setting for a machine with small brake canisters is 120 psi (8.2 bar).

The system air pressure will move back and forth between the pressure setting and less than 20 psi (1.38 bar) lower. The compressor will come on when the pressure decreases the predetermined set point and will turn off when the pressure reaches a predetermined set point. The difference between high and low is called hysteresis and is a characteristic of the governor. If the hysteresis is larger than 20 psi (1.38 bar), the governor is defective and should be replaced.

The air compressor will be compressing for a short time to raise the pressure in a normal air system. It will stop compressing when the pressure reaches the predetermined set point. The system pressure will then slowly decrease depending on air usage by items such as the KLENZ™ system, air horn, air brakes, leaks, etc. The decrease time will be much longer than the compression time in a normally operating air system. The percentage of on time will typically be in the 5-15% range. The actual time compressing and not compressing will depend on air usage in the air system.

NOTICE

The air compressor will provide the most airflow at lower air pressure settings. Raising the air pressure setting will reduce the airflow capability of the air compressor. The air pressure on the machines should be run at the recommended settings.

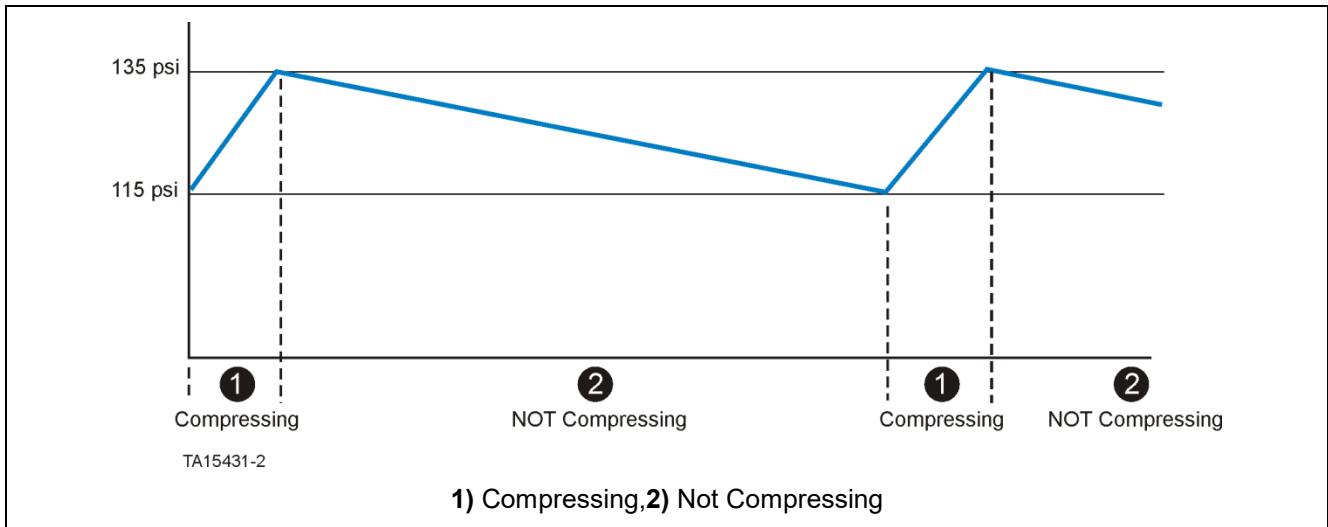

Figure 2. Normal compressor duty cycle

As an example, if a major air leak existed, the compressor could be on for 10 seconds and off for 10 seconds. This does two things:

1. The compressor duty cycle is 50%, which will cause excessive compressor heat and increased wear. The heat and wear will cause the *normal* oil leakage past the rings into the head of the compressor to carbonize, resulting in stuck unloading components and eventual compressor failure.
2. The dryer will not have time to properly purge out moisture and contaminants and these will be passed into the air system.

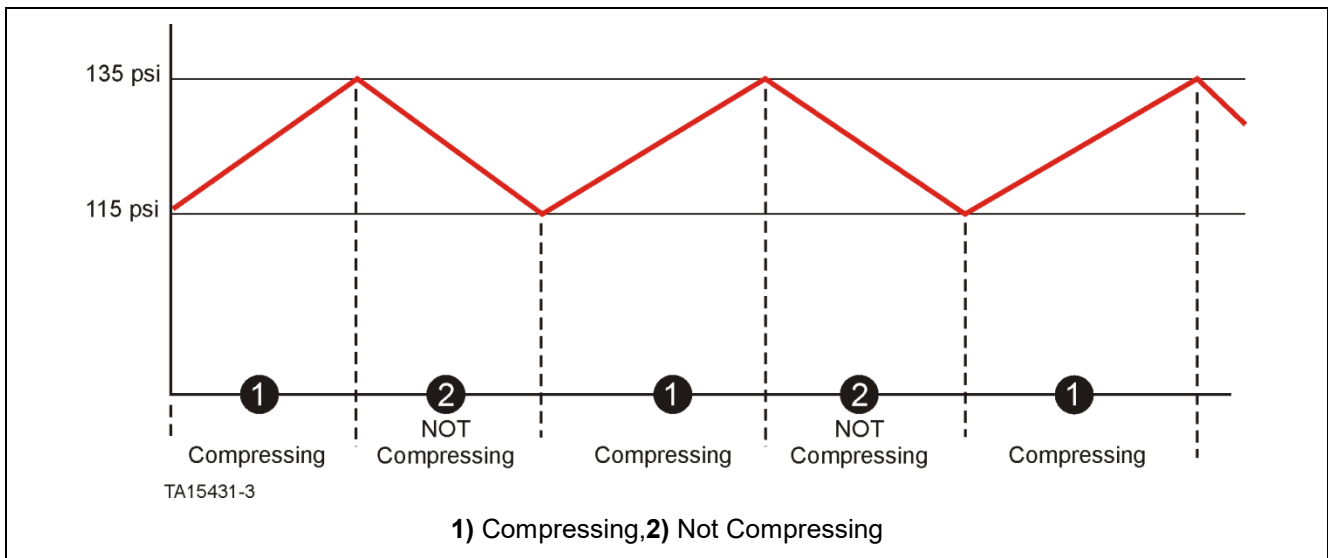

Figure 3. Compressor duty cycle too high duty cycle and too little time off

CAUTION

Testing of the KLENZ™ system, air brakes, air horn, and other air systems for flow requirements with flow meters, by this example, would indicate that the compressor currently in use does not have the capacity to cope with a major continuous air leak. All leaks should be fixed as soon as possible.

Compressed Air System Leak Detection

When a major air leak occurs in the system, the compressor duty cycle increases. Depending on the severity of the leak, the entire capacity of the compressor could be lost. Two common areas for major leaks are identified as being the hydraulic reservoir and the KLENZ™ system. Both of these areas are isolated from the main air system by solenoids, orifices, and regulators.

- The solenoids will stop airflow to both areas when the machine is booted down for maintenance and any air leaks will not be heard.
- KLENZ™
 - The KLENZ™ system is isolated behind an orifice in the air line to prevent surges in the main air system when the KLENZ™ valves pulse.
 - However, this orifice also limits airflow to the KLENZ™ system so if there is a major air leak in the KLENZ™ system the compressor will typically be able to maintain main system pressure so the machine can continue to operate but at a very high compressor duty cycle.

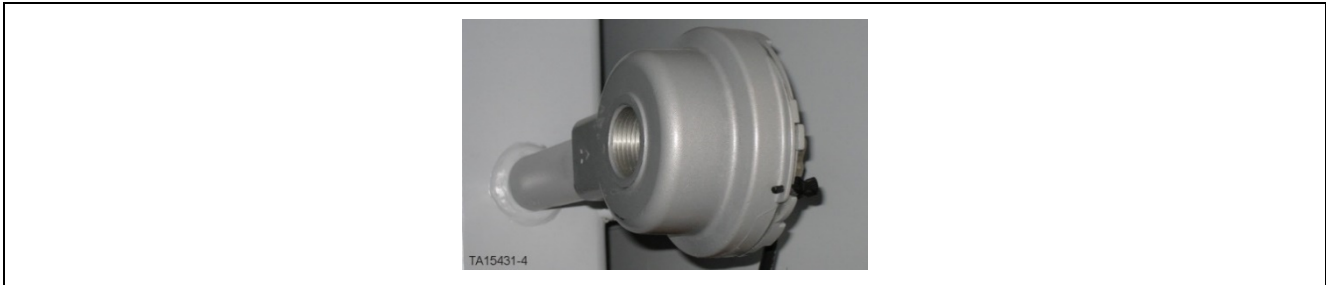

Figure 4. Diaphragm valve

NOTICE

Before beginning the process of troubleshooting the Compressed Air System, the technician/operator must be proficient in the use of LINCS. The LINCS system can be used to obtain a numerical or graphical readout of the pressures of each section of the Compressed Air System (described below).

The compressed air system can be considered as three sections; **Distribution** (System Air Pressure), **Front Brake** (Park Brake Pressure Front), and **Rear Brake** (Park Brake Pressure Rear). Because of the location of check valves and pressure transducers in the Compressed Air System, the process of elimination can be used to quickly identify the most likely source for an air leak in the overall Air System.

Use an ultrasonic air leak tester to test the system for air leaks during normal maintenance intervals. This has been factory and field tested and has been proven to make air leak detection very quick and accurate. There are many models of ultrasonic leak detectors available. The factory has used an Inficon Whisper that is low cost but works very well for detecting air leaks. This is available from Komatsu under P/N R4264953 and local distributors as Inficon P/N 711-202-G1.



Figure 5. Ultrasonic leak detector (P/N R4264953)

LINCS II Troubleshooting Conditions

- LINCS system booted up (the engine is not running).
- The air system is pressurized to normal operating pressure.

NOTICE

The compressed air system can be pressurized by either cranking and running the engine until the air system pressurizes or pressurizing the system by using appropriate, externally supplied compressed air connected through the manual air valve located below the high voltage electrical cabinet.

Once the above troubleshooting conditions are met, use the LINCS II menu to navigate to the channel selection screen and select the channels for the **System Air Pressure, KLENZ™ Reservoir Air, Hydraulic Reservoir, Park Brake Pressure Front, and Park Brake Pressure Rear.**



Figure 6. LINCS II channel selection screen (typical screen)

Navigate to the Charting screen. The Charting screen provides a way to view channel data in a plot or strip chart form. Multiple channels can be displayed showing data “live” (as it occurs) or “history” (from previous time).

For more information on charting, refer to Section 06 “ELECTRICAL SYSTEMS, LINCS” of the Service Manual.

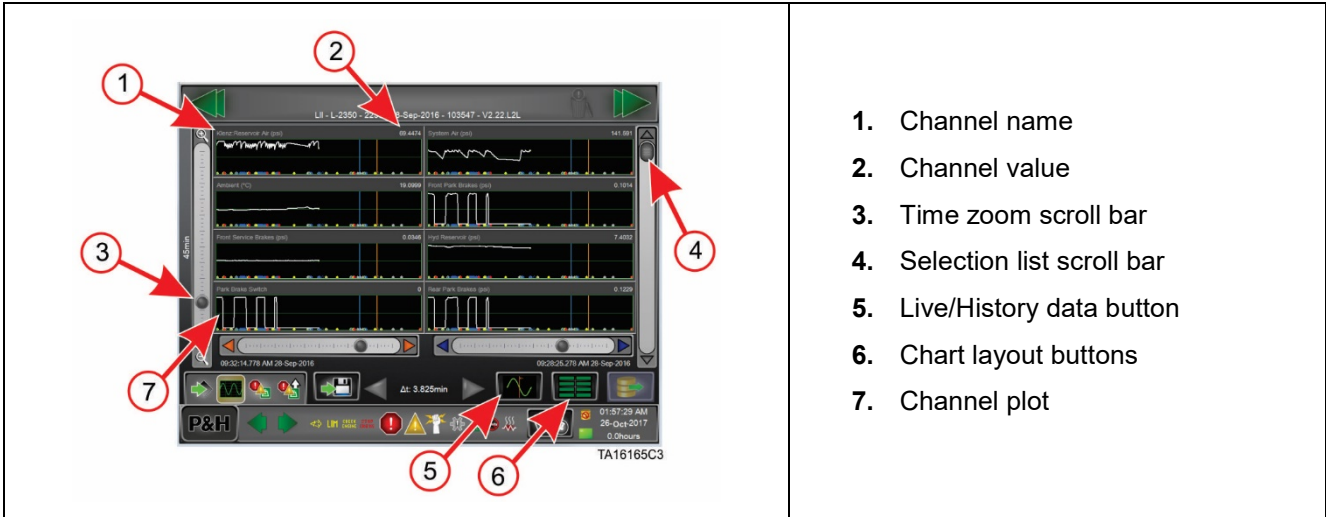

- 1. Channel name
- 2. Channel value
- 3. Time zoom scroll bar
- 4. Selection list scroll bar
- 5. Live/History data button
- 6. Chart layout buttons
- 7. Channel plot

Figure 7. LINCS II charting screen (typical screen)

This Page Intentionally Left Blank

VCU LOGIC

See Circuit Specific Sheets

Notes

The force inputs/outputs functions provide advanced testing functionality. These actions allow the technician with Service Level Access or greater to force either inputs or internal channels of the VCU to a known state. This is an advanced function that is not needed for the diagnosis of most machine issues. Several forces are available via the maintenance screen. All other forces are available only through the channel browser.

ADJUSTMENTS

ELECTRIC

AIR

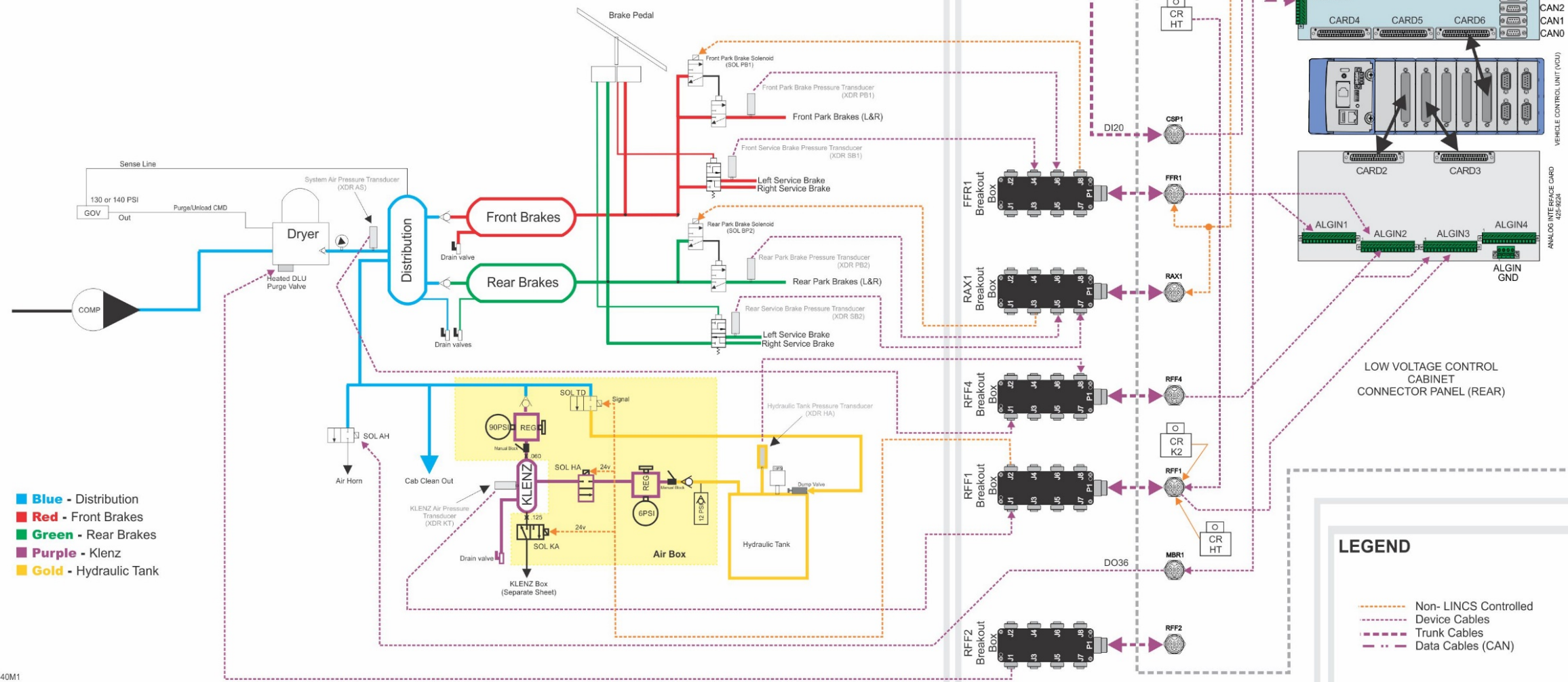

Complete Air System

Gen3

Figure 8. Complete air system

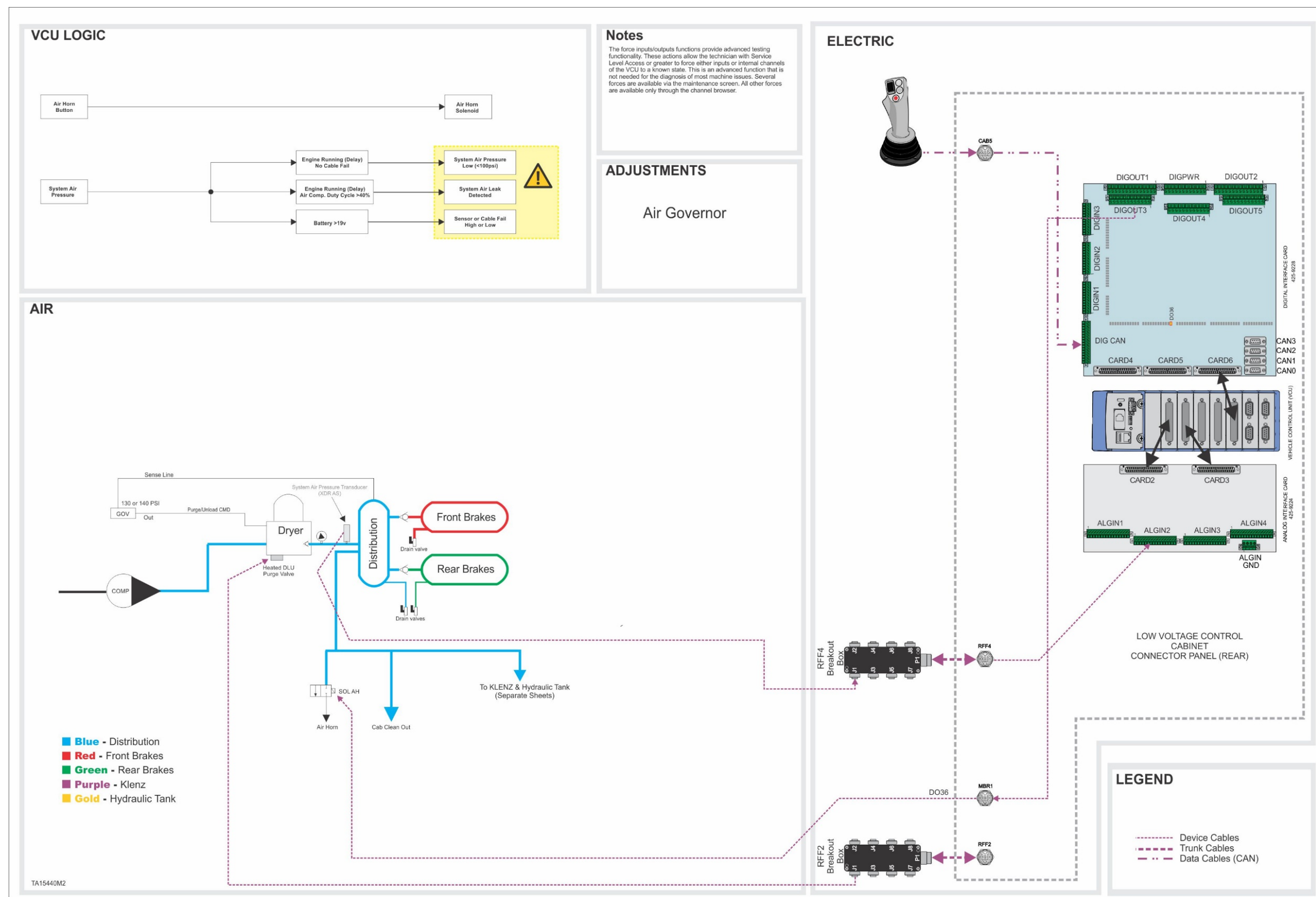

Air Distribution System

Gen3

Figure 9. Air distribution system

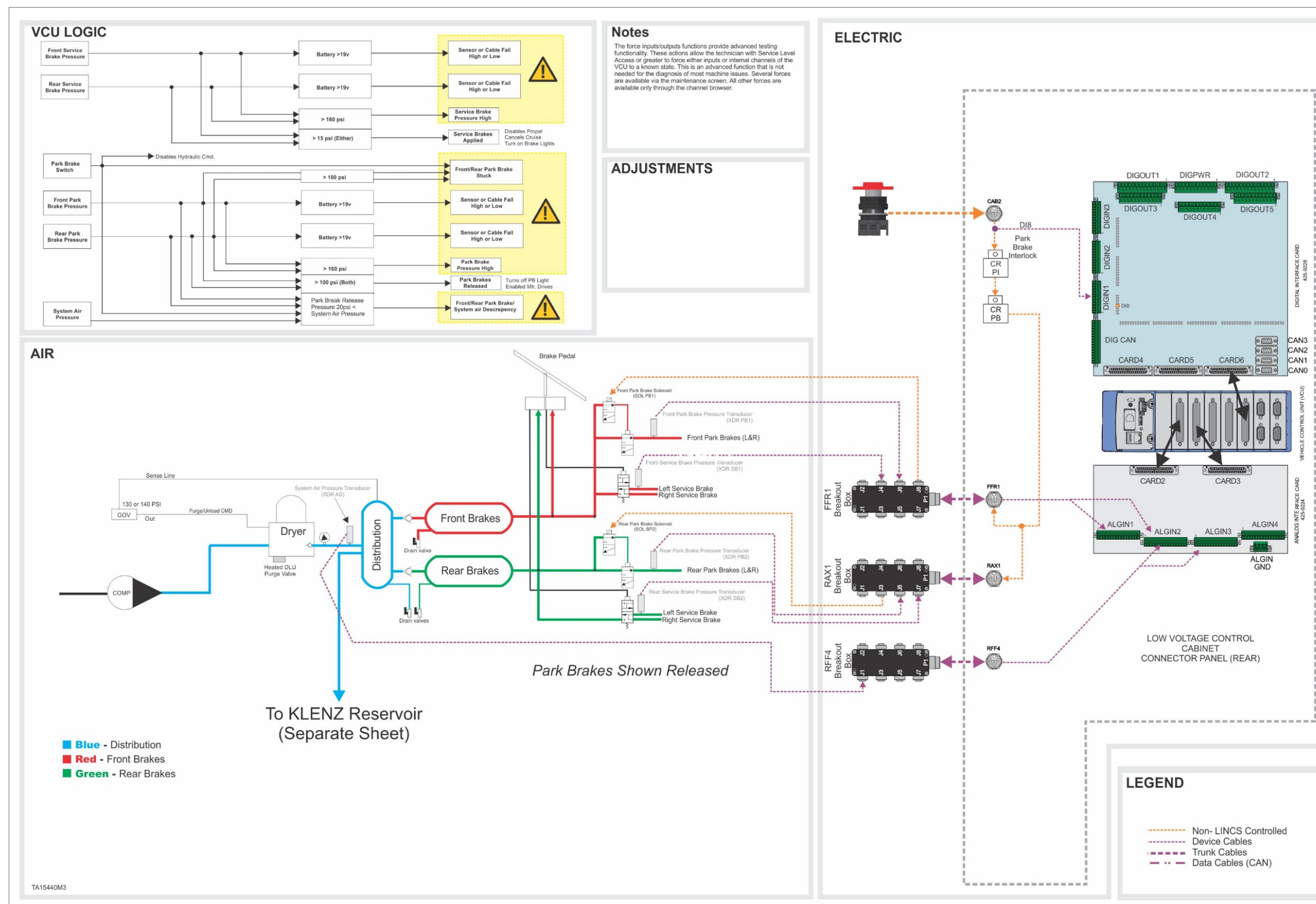

Brake System

Gen3

Figure 10. Brake system

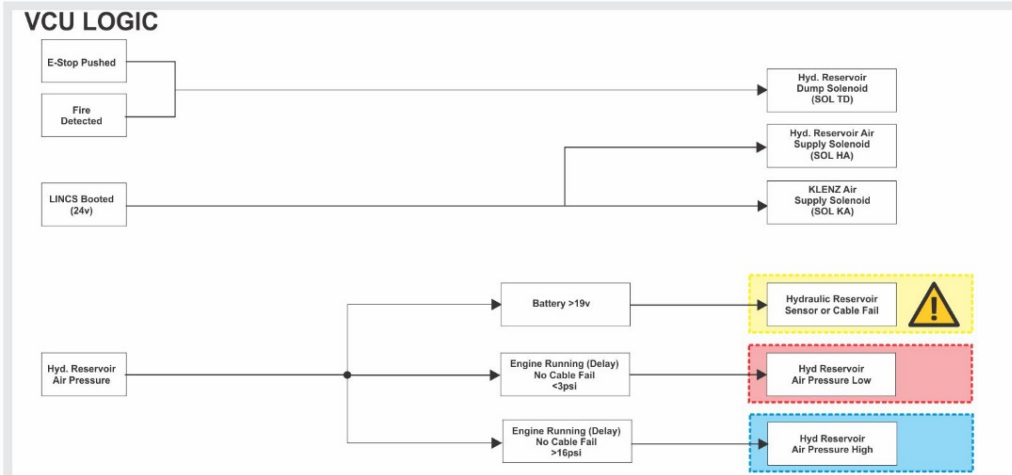

Notes

The force inputs/outputs functions provide advanced testing functionality. These actions allow the technician with Service Level Access or greater to force either inputs or internal channels of the VCU to a known state. This is an advanced function that is not needed for the diagnosis of most machine issues. Several forces are available via the maintenance screen. All other forces are available only through the channel browser.

ADJUSTMENTS

- Hydraulic tank air regulator
- KLENZ Regulator

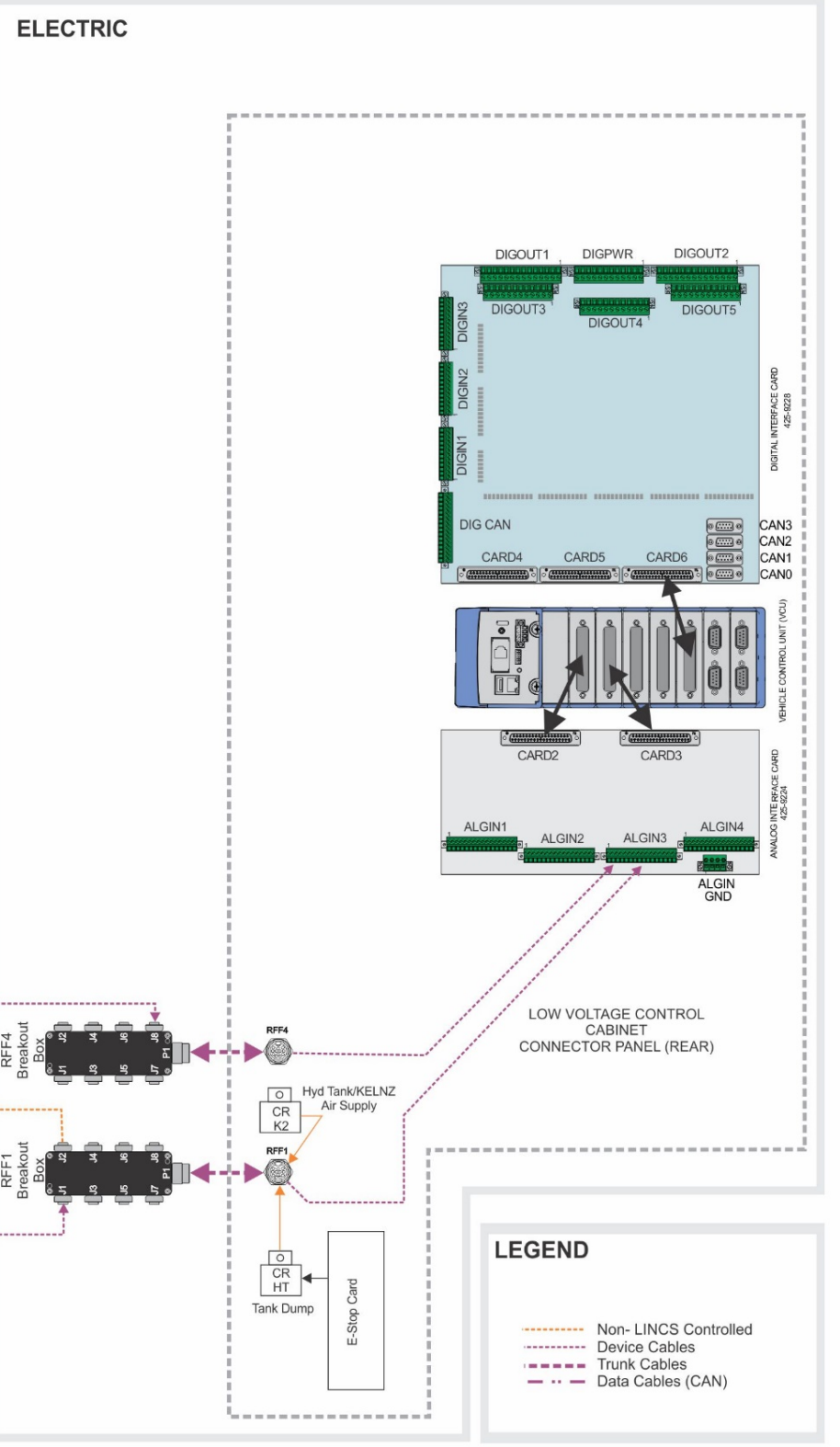
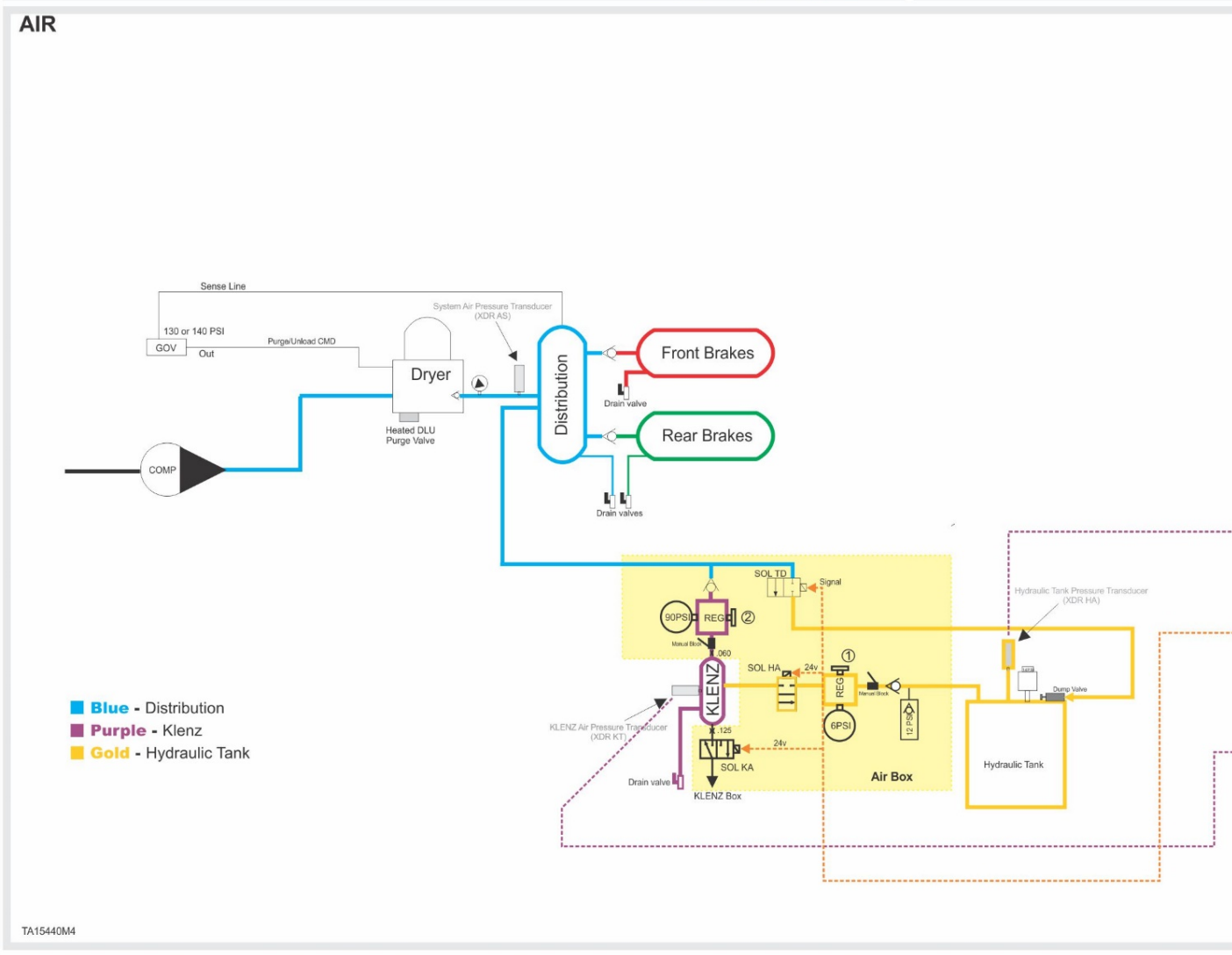

Hydraulic Tank System

Gen3

Figure 11. Hydraulic tank system

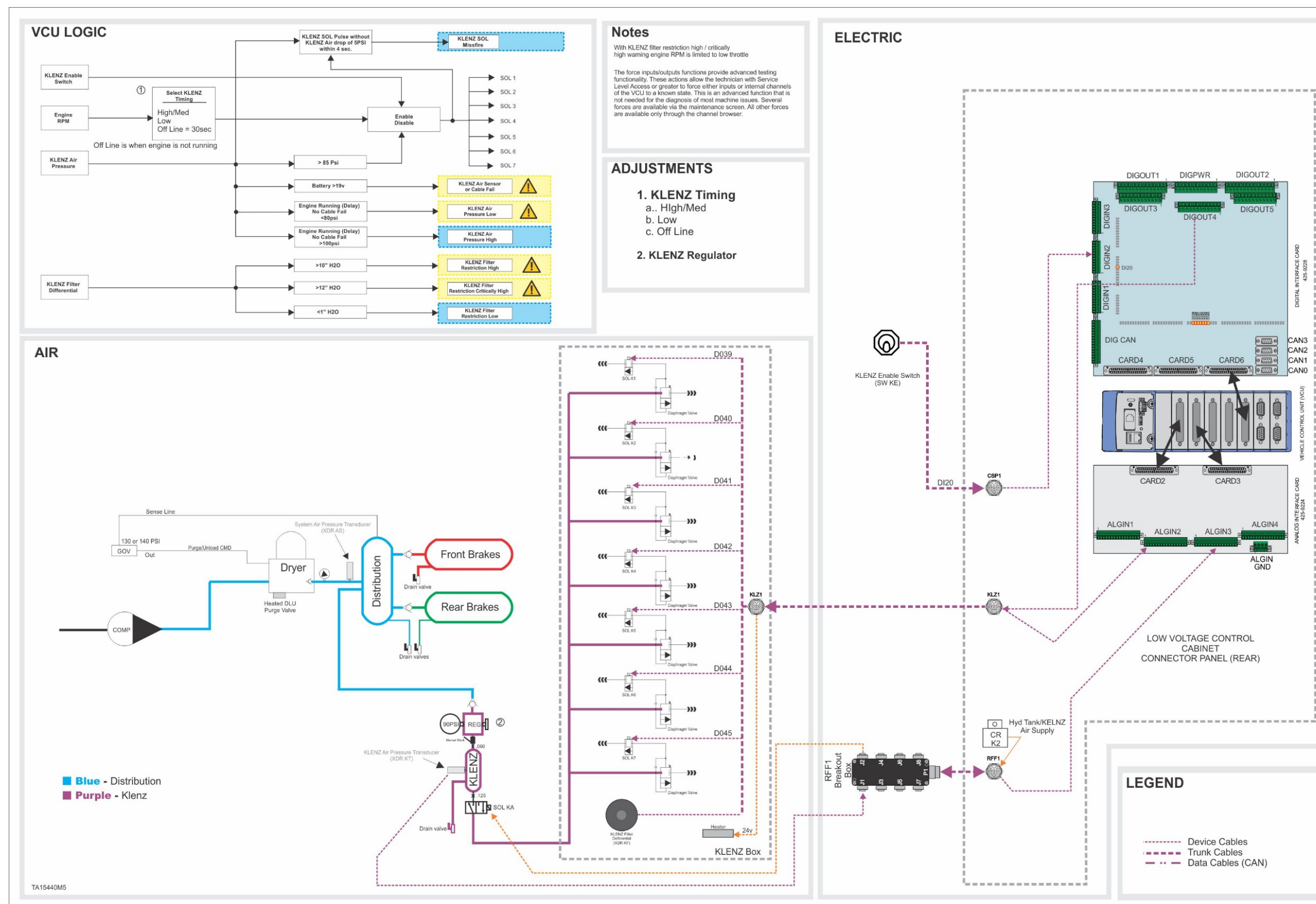

Figure 12. KLENZ™ system

KLENZ System

Gen3

This Page Intentionally Left Blank

Troubleshooting Procedure to Isolate a Difficult to Find Air Leak

System Air Pressure Low (Previously verified that this is not a LINCS problem such as cable or transducer)

How to use the troubleshooting table:

1. Answer the question in the initial step
2. If the answer is YES go to the step indicated in the YES column
3. If the answer is NO go to the step indicated in the NO column

SYSTEM AIR PRESSURE LOW Troubleshooting procedure			
STEP	QUESTIONS	YES	NO
3	The Air System has a pressure of <100 psi. LINCS components have been verified as working properly.	4	Possible Causes
4	Ensure that all air tank drain valves are closed and KLENZ™ power switch is turned off and that KLENZ™ is not firing. Does the warning only occur when the service brakes are applied?	28	23
5	Kill the engine then release park brake. Allow System Air Pressure to stabilize for 30 seconds. Examine the following channels in LINCS: System Air Pressure, Front PB Pressure, Rear PB Pressure, KLENZ™ Pressure. Do you see a pressure drop of one psi per minute or more on any channel?	6	Inspect the Inlet and Outlet lines of the Compressor for damage or restrictions. If none are present, replace the compressor.
6	Does the pressure drop occur only on the System Air Pressure channel?	10	7
7	Does the pressure drop occur on both the System Air Pressure and the KLENZ™ Air Pressure channels?	16	8
8	Does the pressure drop occur on both the System Air Pressure and the Front PB Pressure channels?	22	9
9	Does the pressure drop occur on both the System Air Pressure and the Rear PB Pressure channels?	24	5
10	Kill the engine and bleed system air pressure to 0 psi. Remove the tee fitting feeding the miscellaneous air system components and plug the tank [X size fitting]. Restart the Engine or use shop air to pressurize the system to full pressure. Does the System Air Pressure channel continue to report dropping air pressure?	15	11

SYSTEM AIR PRESSURE LOW Troubleshooting procedure			
STEP	QUESTIONS	YES	NO
11	Kill the engine and bleed system air pressure to 0 psi. Reinstall the tee fitting feeding the miscellaneous air system components and plug all but one of the tee'd component lines [X size fitting]. Restart the Engine or use shop air to pressurize the system to full pressure. Does the System Air Pressure channel report dropping air pressure now?	12	13
12	The leak is most likely the circuit that has been added. Kill the engine and bleed system air pressure to 0 psi. Trace the circuit to the component, remove the component and cap or plug the component. Restart the Engine or use shop air to pressurize the system to full pressure. Does the System Air Pressure channel to report dropping air pressure now?	Replace the hose between the distribution tank and component.	Replace the component.
13	Kill the engine and bleed system air pressure to 0 psi. Remove the plug for the next component and connect the component line to the tee. Restart the Engine or use shop air to pressurize the system to full pressure. Does the System Air Pressure channel report dropping air pressure now?	12	14
14	Kill the engine and bleed system air pressure to 0 psi. Remove the plug for the last component and connect the component line to the tee. Restart the Engine or use shop air to pressurize the system to full pressure. Does the System Air Pressure channel report dropping air pressure now?	12	The problem was most likely a loose fitting that has been tightened during the course of troubleshooting. If you are unsure of the solution repeat the process.
15	With the engine NOT running and the Distribution Tank fully charged, inspect the output of the Air Dryer. Is air escaping from the purge port of the dryer?	Replace the check valve located on the output of the Air Dryer.	25
16	The regulator feeding the hydraulic tank should be set to six psi. Is this true?	17	Adjust to six psi and recheck.
17	Kill the engine and bleed system air pressure to 0 psi. At the KLENZ™ tank, plug the line supplying air to the hydraulic tank circuit. Restart the Engine or use shop air to pressurize the system to full pressure. Does the KLENZ™ Air Pressure channel still report dropping air pressure?	21	18
18	Close the ball valve located on top of the Hydraulic Tank. Does the KLENZ™ Air Pressure channel still report dropping air pressure?	19	Use ultrasonic leak detector. Leak is isolated to the Hydraulic Tank and related components. Check the following: Cap, Dump Valve, Filler Cap, etc.
19	Is the 12 psi check valve leaking?	Replace Check Valve	20

SYSTEM AIR PRESSURE LOW Troubleshooting procedure			
STEP	QUESTIONS	YES	NO
20	Use soap and water or ultrasonic leak detector. Is the Hydraulic Tank Supply solenoid leaking?	Repair or Replace Solenoid	Problem exists in hose between KLENZ™ tank and regulator. Repair or replace hose/fitting.
21	Kill the engine and bleed system air pressure to zero psi. At the KLENZ™ tank, plug the leaving the solenoid going to the KLENZ™ box. Restart the Engine or use shop air to pressurize the system to full pressure. Does the KLENZ™ Air Pressure channel still report dropping air pressure?	There is a leak in the KLENZ™ tank system. Inspect the regulator, solenoid valve, and the tank and associated fittings. Repair this leak and recheck.	Use ultrasonic leak detector. Leak is isolated to the KLENZ™ Box and related components. Check the following: Pulse Solenoid, Pulse Valves, Diaphragms, Lines. etc.
22	With the Park Brakes released, is the Front Park Brake Relay Valve leaking air from the exhaust port?	Repair or Replace the Front Park Brake Relay Valve.	Check for Leaks in the hoses between PB Relay Valve and the Brake Canister.
23	The governor setting should be 135 psi. When 135 psi is reached the governor shifts the purge valve in the dryer and unloads the outlet of the compressor. In LINCS browse the System Air Pressure channel. Does the System Air Pressure build to 135 psi and then stabilize?	5	30
24	With the Park Brakes released, is the Rear Park Brake Relay Valve leaking air from the exhaust port?	Repair or Replace the Rear Park Brake Relay Valve.	Check for Leaks in the hoses between PB Relay Valve and the Brake Canister.
25	Kill the engine and bleed system air pressure to zero psi. Remove the line feeding the Front Brake tank and plug the Distribution tank [X size fitting]. Restart the Engine or use shop air to pressurize the system to full pressure. Does the System Air Pressure channel continue to report dropping air pressure?	26	Replace the hose from the Distribution Tank and the Front Brake Tank.
26	Kill the engine and bleed system air pressure to zero psi. Remove the line feeding the Rear Brake tank and plug the Distribution tank [X size fitting]. Restart the Engine or use shop air to pressurize the system to full pressure. Does the System Air Pressure channel continue to report dropping air pressure?	27	Replace the hose from the Distribution Tank and the Rear Brake Tank.
27	Kill the engine and bleed system air pressure to zero psi. Remove the line feeding the KLENZ™ tank and plug the Distribution tank [X size fitting]. Restart the Engine or use shop air to pressurize the system to full pressure. Does the System Air Pressure channel continue to report dropping air pressure?	The problem is either the tank or the tank safety relief valve. Use soap and water to detect leaks.	Replace the hose from the Distribution Tank and the inlet of the KLENZ™ Pressure Regulator.

SYSTEM AIR PRESSURE LOW Troubleshooting procedure			
STEP	QUESTIONS	YES	NO
28	Charge the air system to 135 psi [engine running or shop air if this air pressure level is available]. Examine the following channels in LINCS: System Air Pressure, Front Service Brake Pressure, and Rear Service Brake Pressure. Apply the service brake pedal and hold constant, do you see a decline in Front Service Brake Pressure?	There is a leak in the Front Service Brake system. In the front axle, inspect the Service Brake Relay Valve and Canisters. Under the Cab inspect the Treadle Valve. Repair this leak and recheck.	29
29	Follow same procedures as in the previous step. Do you see a decline in Rear Service Brake Pressure?	There is a leak in the Rear Service Brake system. In the rear axle, inspect the Service Brake Relay Valve and Canisters. Under the Cab inspect the Treadle Valve. Repair this leak and recheck.	Please restart the test procedure, some element may have been missed.
30	Are you able to adjust the governor to achieve 135 PSI?	Done	31
31	Remove and replace the governor. Does this fix the problem?	Done	5
32	Use LINCS to inspect the channels for System Air Pressure, Front and Rear Park Brake pressure. With the park brakes released are the reported air pressures relatively equal [$\pm 10\%$]?	6	33
33	Remove and replace the transducer for the channel that was not equal to the others [System Air Pressure, Front and Rear Park Brake Pressure]. Does this fix the problem?	Done	There is a problem with the Remote Module signal processing. Replace the Remote Module.